

BRIEF INSTRUCTIONS

IB-C30-HV



JJ X-RAY
Danish Science Design

IB-C30-HV

This is the classic JJ X-Ray slit, adapted for vacuum applications where O-ring sealing is sufficient.

The aperture is defined by four independently movable, highly polished tungsten carbide blades. These blades are controlled by a high precision guiding rail system and high resolution stepping motors.

The blades can be installed in two configurations, either providing a curved surface of radius 16 mm or providing a knife-edge sloping at 0.5 degrees. Standard blades are polished to obtain a roughness better than 25 nm RMS.

In its basic configuration, the slit is delivered with a flange-opening and four tightening bolts to allow connection with a KF-40 flange.

Technical Specifications

IB-C30-HV	
Aperture size	Maximum: 30 mm x 30 mm Minimum: Full overlap
Resolution	1 micron per full step
Repeatability	< 1 micron
Accuracy	± 2 micron (over 3 mm)
Vacuum	O-ring sealed, high vacuum 10 ⁻⁵ mbar, low outgassing materials
Mechanical dimension	193 mm x 193 mm x 68 mm 120 mm x 120 mm x 64 mm (housing only)
Standard blades	2 mm thick tungsten carbide blades, can be mounted either with 0.5 degree knife-edge or R16 radius edge
Mechanical connections	M5-threaded holes on the sides as shown on the drawing. KF-40 flange connections are provided on the body of both sides of the slit
Limit switches (end-of-travel)	Included as standard on all motions
Weight	≈ 4.0 kg
Outer surface	Anodized aluminum in color nature
Guiding	High precision internal rails and carriages
Electrical connections	Microswitches coupled to 2 motor connectors (SUB-D 15 pins male)
Motors	2 phase stepping motors

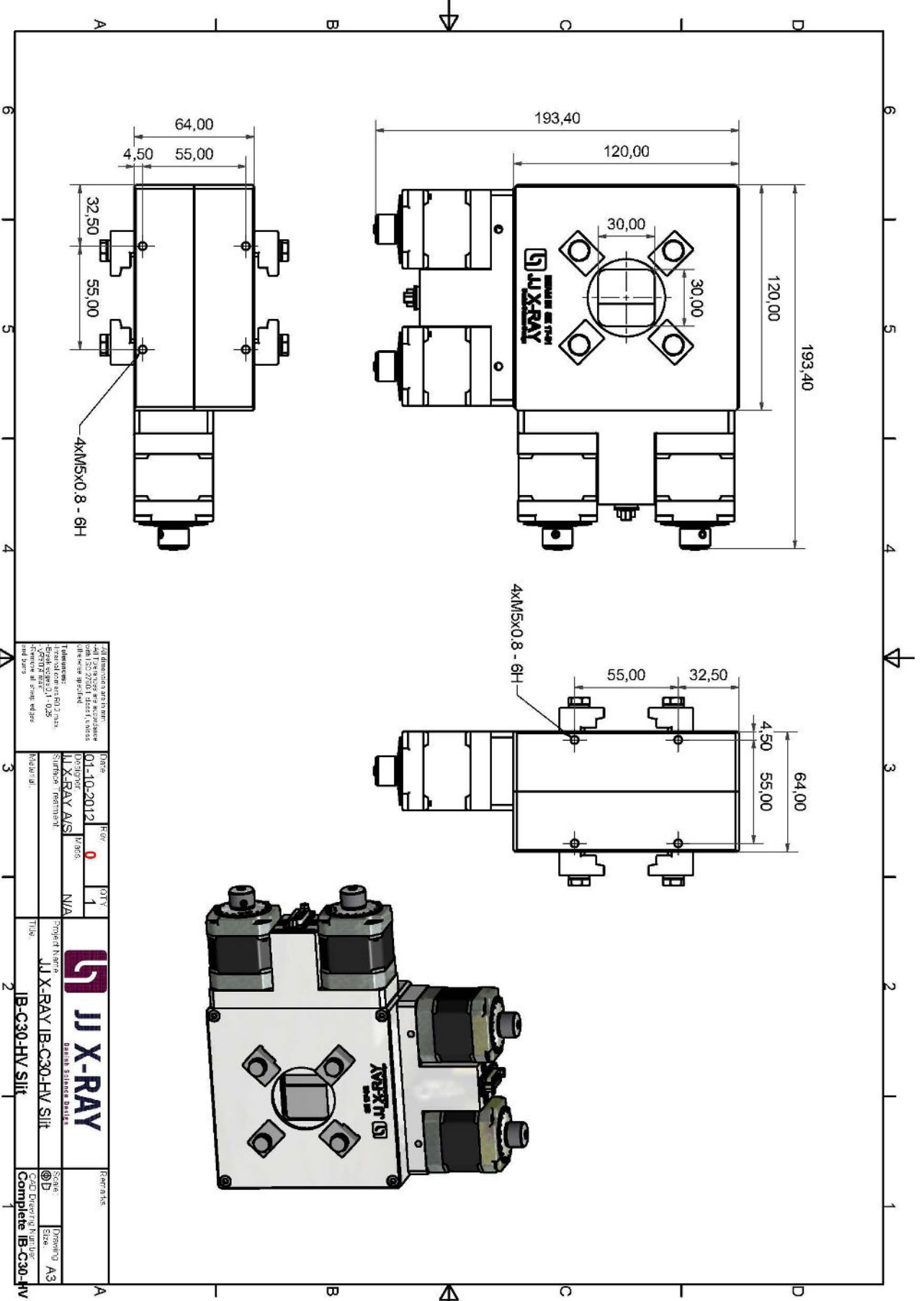

All dimensions are in mm. Tolerances are as follows: ±0,10 for dimensions < 100 mm, ±0,15 for dimensions > 100 mm. All dimensions are in mm. Tolerances are as follows: ±0,10 for dimensions < 100 mm, ±0,15 for dimensions > 100 mm.		Date: 01-10-2012	Rev: 0	QTY: 1	Part No: N/A	Part Name: JJ X-RAY IB-C30 HV Sliit	Part No: N/A	Part Name: JJ X-RAY IB-C30 HV Sliit	
Title: JJ X-RAY IB-C30 HV Sliit		Author: JJ X-RAY AIS	Checked: JJ X-RAY AIS	Approved: JJ X-RAY AIS	Scale: A3	Scale: A3	Scale: A3	Scale: A3	
Comments: Complete IB-C30-HV		Comments: Complete IB-C30-HV		Comments: Complete IB-C30-HV		Comments: Complete IB-C30-HV		Comments: Complete IB-C30-HV	

Inside slit

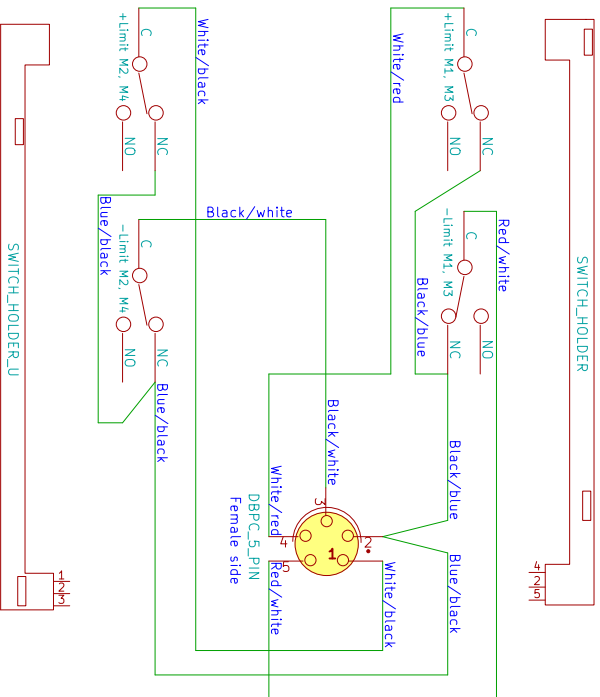

Motor flange

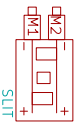
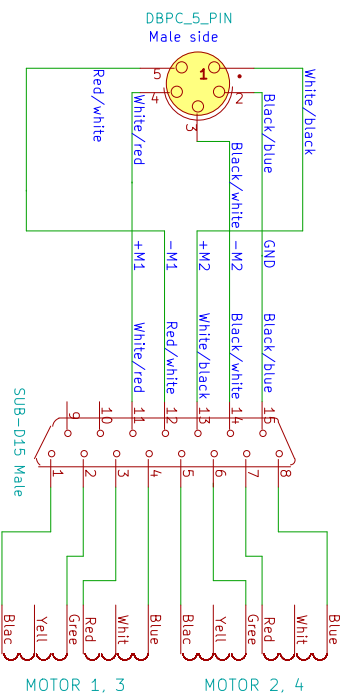

Ingen strips om fischer D 22.08.2017 CM, HBP

JJ X-Ray Michael Andersen

File: ibc30hv_01d_wfresch

Sheet: /

Title: IB-C30-HV

Size: A4 Date: 9 Jan 2018

Kicad E.D.A. eeschema (2013-05-16 BZR 4016) - stable

Rev: 1.0
Id: 1/1

Motor Specifications

Motor Specifications	
Number of motors	4
Motor type	2-phase stepping motor
Manufacturer	Oriental Motors
Motor make	PKP244MD15B
Step angle	0.9°
Connection type	Bipolar (Serial)
Current per phase	1.5 A/phase
Resistance	2.6 Ω /phase
Inductance	7.6 mH/phase
Limit switches	'+' and '-' end of travel

Motion Mechanism	
Type of motion	Translation
Guidance	In vacuum rails and carriages
Motor step angle	0.9°/step
Motor gear	None
Lead screw pitch	0.4 mm/rev
Scale factor	1000 steps/mm
Mechanical resolution	1 μ m/step
Translation calibration	1 μ m/step

Recommended Driver Settings	
The motors should be run <u>at 1.5 A per phase.</u> The motors have been tested at:	
Running speeds	1000 steps/second
Starting speeds	300 steps/second
Ramp times	0.1 second

Always use “backlash correction” if available (i.e. the motor always approaches the final position from the same side). A useful backlash parameter could be 0.1 mm.

Warning:

If you are using systems/detectors that can be damaged by overexposure, where the slits are used to remove a lot of the intensity, be careful when changing aperture size since the backlash correction may result in the slit being opened significantly more than you anticipated during adjustment.

Manual Control

If for some reason, you need to move the slit blades manually, it is possible to use the scale wheel attached to the back shaft of the motor. It is probably easiest, if this operation is done with an open cover so you can see what is going on.

The manual control is not possible in slit-versions with back shaft encoders or slit versions mounted with IMS motors.

Limit Switches

The limit switches should be wired up, if at all possible. There is always some ambiguity in the definition of the travel direction. The first time you test the slits and cables you should therefore open up the slit and test the actual functioning of the limit switches. Below we show an image that may help you in determining the appropriate limit switch setup.

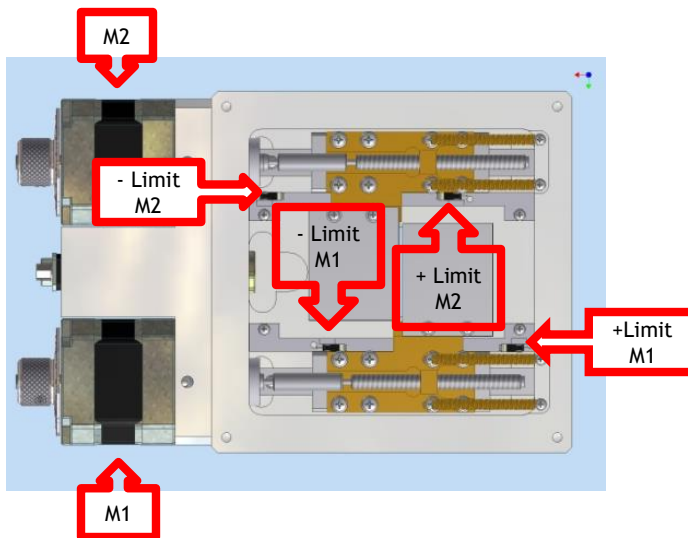

Mechanical overview of limit switch position

Trouble Shooting

The most common issues and their resolutions are:

- ❏ The motor does not move when it should (it can be silent, be jittering or be making a noise).
 - The motor is not receiving enough current. Try setting the current a bit higher (for example 10%). If problems persist check with an amp-meter to see that your driver is working properly.
 - The wiring is bad. Check cabling.
 - One of the motors' phases is burnt. Check that the resistance on all phases is the same. If not, contact us to have the slit sent for repair.
 - The motor is stuck against a limit switch. Un-stick it, using the scale wheel or, if an AT-slit, open the slit (see manual control), and fix the limit switch issue.
- ❏ Restart the controller and the controller program.
- ❏ The blade system shows irreproducibility during operation.
 - The rail system may have become loose. Open the slit. Check if the rail-system is tight. Tighten screws if you need to.

Common options

- ❏ Blade options: 4, 5, 10 mm, other blade materials.
- ❏ Motors: Custom high resolution stepping motors, including IMS motors.
- ❏ Encoders: Back-axle rotary encoders.
- ❏ Connectors: Adaptors to other KF (NW) flanges or CF flanges can be provided.
- ❏ Special preparation for enabling vacuum <10⁻⁶ mbar.

The JJ X-Ray Product Range

- ☒ Slit Systems (AIR, HV, UHV)
- ☒ Complete Beamline Solutions
- ☒ Spectrometers
- ☒ Refractive Optics
- ☒ Foil Collimators
- ☒ Positioning

Contact JJ X-Ray A/S

If you have any questions, concerns, request for quotations or need general advice, please feel free to contact us:

JJ X-Ray A/S
Scion-DTU, Dr. Neergaards Vej 5D
2970 Hoersholm
Denmark

Telephone: +45 4776 3000
Fax: +45 4776 3001
VAT: DK 29523215

info@jjxray.dk
sales@jjxray.dk
Website: www.jjxray.dk