

BRIEF INSTRUCTIONS

IB-C140-AIR

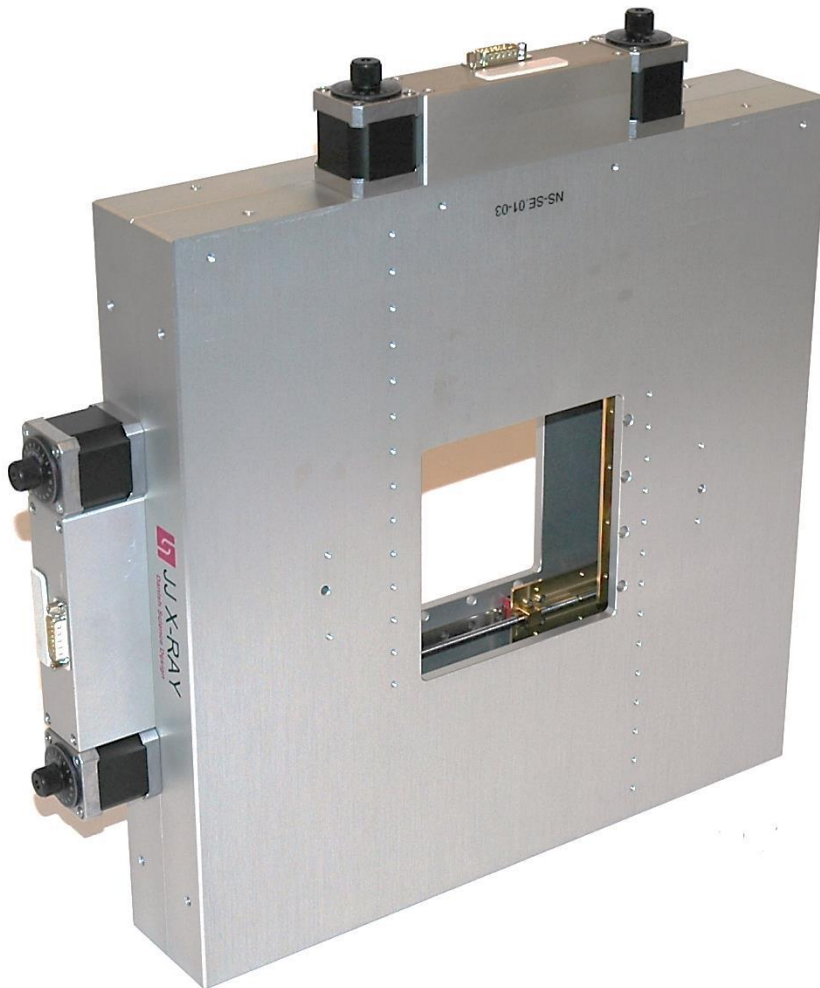

JJ X-RAY

Danish Science Design

IB-C140-AIR

Our largest standard slit system to date, so far having found application primarily in the neutron community. The slit system uses the same concepts as the other IB-slits but has been reinforced to handle the significantly larger and heavier blades.

The standard blades are B4C or tungsten carbide of 5 mm thickness. Other blades can be accommodated or provided by the customers themselves.

Technical Specifications

IB-C140-AIR	
Aperture size	Maximum: 140 mm x 140 mm Minimum: Full overlap
Resolution	1 micron per full step
Repeatability	< 2 micron
Accuracy	± 10 micron over full range ± 1 micron or better with encoders
Mechanical dimension	495 mm x 495 mm x 82 mm 434 mm x 434 mm x 78 mm (housing only)
Mechanical connections	M6-threaded holes on the sides as shown on the drawing.
Limit switches (end-of-travel)	Included as standard on all motions
Weight	≈ 12 kg
Outer surface	Anodized aluminum in color nature
Guiding	High precision internal rails and carriages
Electrical connections	Microswitches coupled to 2 motor connectors (SUB-D 15 pins male)
Motors	2 phase stepping motors

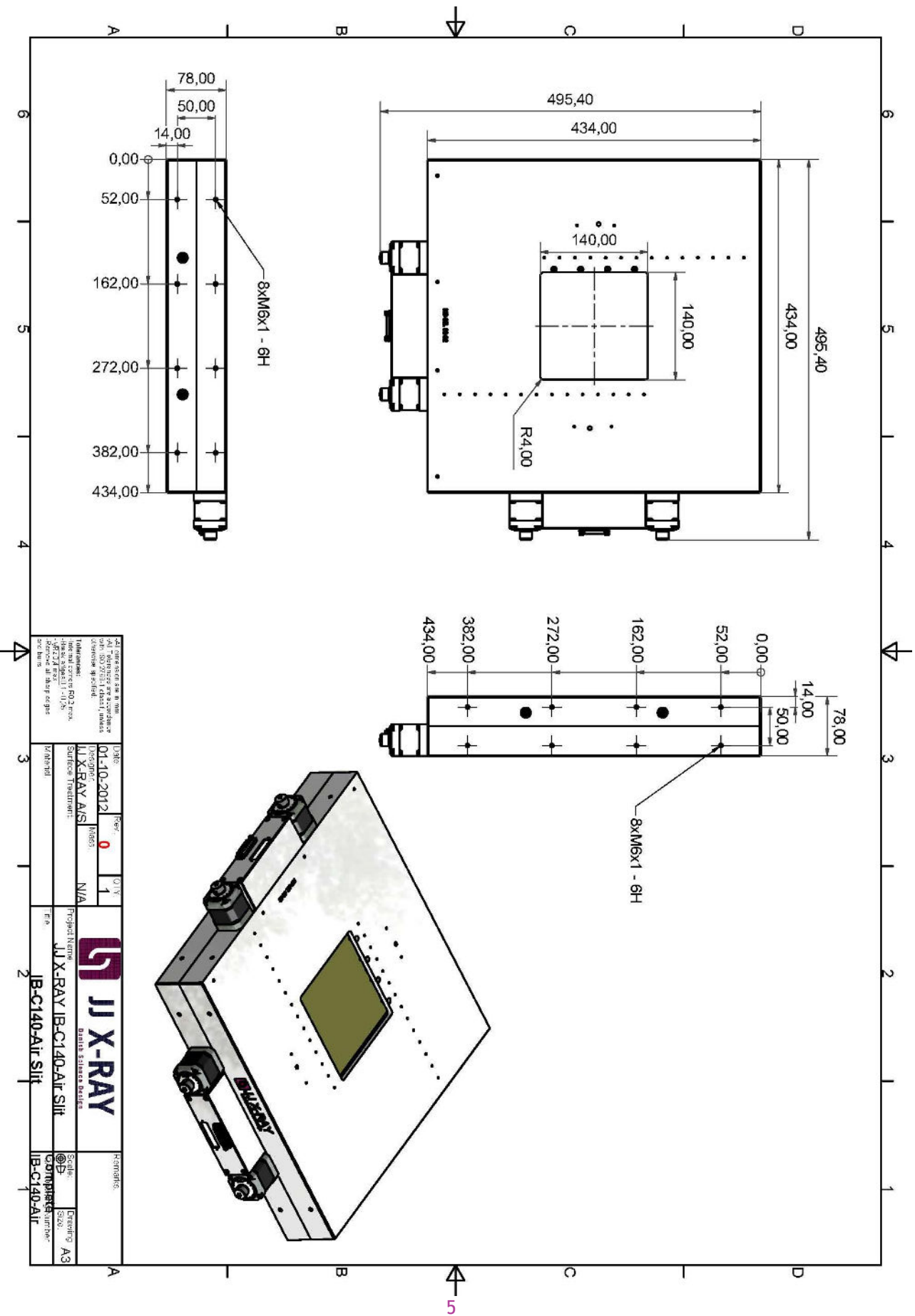

1. All dimensions are in mm. 2. All references are according to o.d.n. S07263-14 direkt, unless otherwise specified.		Date: 01-10-2012 Designer: JJ X-RAY/AS Surface Treatment:	Order No: 0 Qty: N/A	 Project Name: JJ X-RAY IB-C140-Air Sift Part: IB-C140-Air Sift	Scale: 1:1 Drawing No: IB-C140-AIR
3. All dimensions are in mm. 4. All references are according to o.d.n. S07263-14 direkt, unless otherwise specified.		Date: 01-10-2012 Designer: JJ X-RAY/AS Surface Treatment:	Order No: 0 Qty: N/A	 Project Name: JJ X-RAY IB-C140-Air Sift Part: IB-C140-Air Sift	Scale: 1:1 Drawing No: IB-C140-AIR

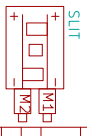
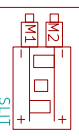
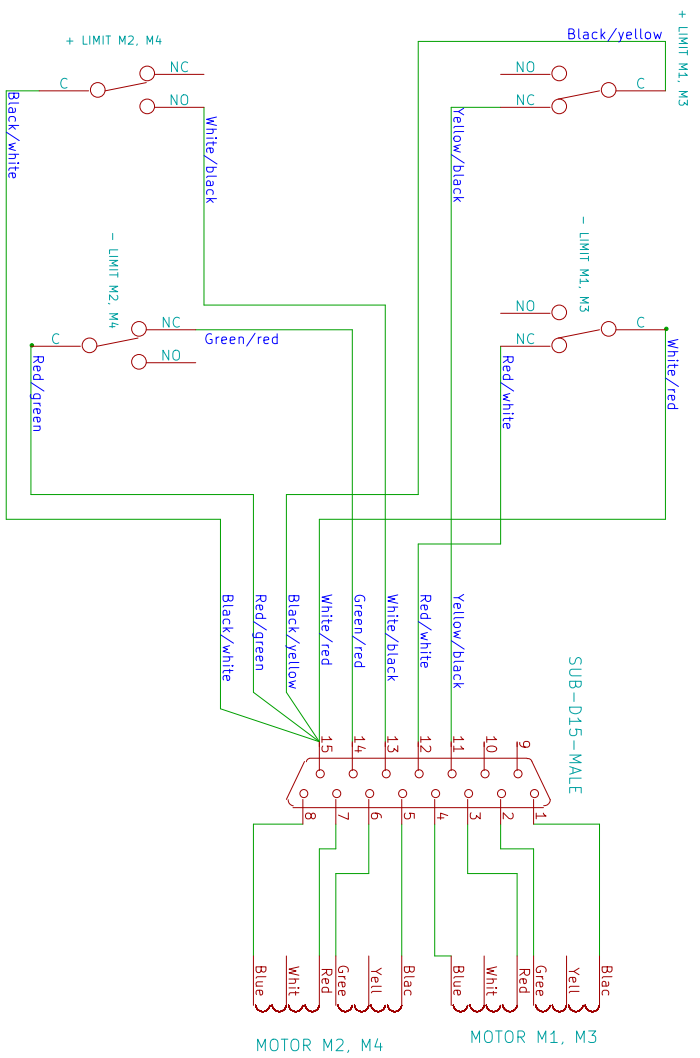

JJ X-RAY Michael Andersen

File: IB-C140-af-rsch

Sheet: /

Title: IB-C140-af-rsch

Size: A4

Date: 9 jan 2018

KiCad E.D.A. eeschema (2013-05-16 BZR 4016)-stable

Rev 1.0

Id: 1/1

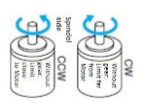

Motor Specifications

Motor Specifications	
Number of motors	4
Motor type	2-phase stepping motor
Manufacturer	Oriental Motors
Motor make	PKP244MD15B
Step angle	0.9°
Connection type	Bipolar (Serial)
Current per phase	1.5 A/phase
Resistance	2.6 Ω/phase
Inductance	7.6 mH/phase
Limit switches	'+' and '-' end of travel

Motion Mechanism	
Type of motion	Translation
Guidance	Linear rails and carriages
Motor step angle	0.9°/step
Motor gear	None
Lead screw pitch	0.4 mm/rev
Scale factor	1000 steps/mm
Mechanical resolution	1 μm/step
Translation calibration	1 μm/step

Recommended Driver Settings	
The motors should be run <u>at 1.5 A per phase.</u> The motors have been tested at:	
Running speeds	1000 steps/second
Starting speeds	300 steps/second
Ramp times	0.1 second

Always use “backlash correction” if available (i.e. the motor always approaches the final position from the same side). A useful backlash parameter could be 0.1 mm.

Warning:

If you are using systems/detectors that can be damaged by overexposure, where the slits are used to remove a lot of the intensity, be careful when changing aperture size since the backlash correction may result in the slit being opened significantly more than you anticipated during adjustment.

Manual Control

If for some reason, you need to move the slit blades manually, it is possible to use the scale wheel attached to the back shaft of the motor. It is probably easiest, if this operation is done with an open cover so you can see what is going on.

The manual control is not possible in slit-versions with back shaft encoders or slit versions mounted with IMS motors.

Limit Switches

The limit switches should be wired up, if at all possible. There is always some ambiguity in the definition of the travel direction. The first time you test the slits and cables you should therefore open up the slit and test the actual functioning of the limit switches. Below we show an image that may help you in determining the appropriate limit switch setup.

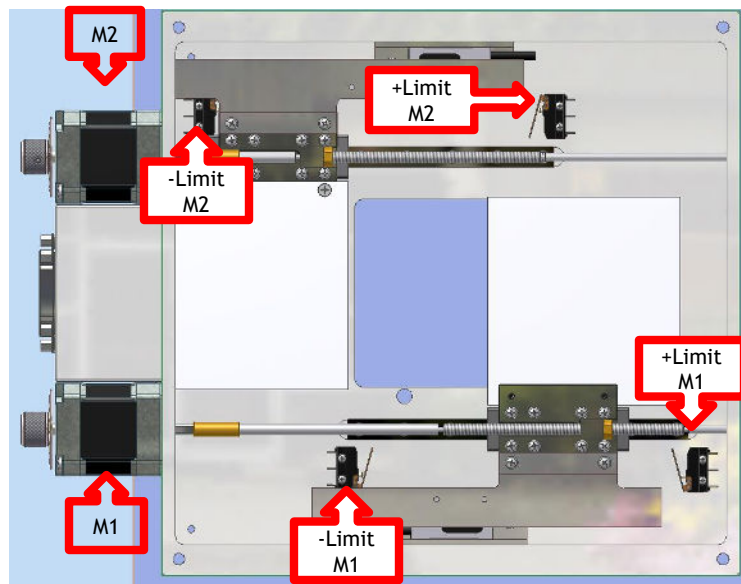

Mechanical overview of limit switch position

Trouble Shooting

The most common issues and their resolutions are:

- ❏ The motor does not move when it should (it can be silent, be jittering or be making a noise).
 - The motor is not receiving enough current. Try setting the current a bit higher (for example 10%). If problems persist check with an amp-meter to see that your driver is working properly.
 - The wiring is bad. Check cabling.
 - One of the motors' phases is burnt. Check that the resistance on all phases is the same. If not, contact us to have the slit sent for repair.
 - The motor is stuck against a limit switch. Un-stick it, using the scale wheel or, if an AT-slit, open the slit (see manual control), and fix the limit switch issue.
- ❏ Restart the controller and the controller program.
- ❏ The blade system shows irreproducibility during operation.
 - The rail system may have become loose. Open the slit. Check if the rail-system is tight. Tighten screws if you need to.

Common options

- ❏ Blade options: Custom blade material and thickness (up to 10 mm).
- ❏ Motors: Custom high resolution stepping motors, including IMS motors.
- ❏ Encoders: Back-axle rotary encoders or Renishaw linear encoders.
- ❏ Non-magnetic guides and lead screws and extension of motor housings for large distance.

The JJ X-Ray Product Range

- ☒ Slit Systems (AIR, HV, UHV)
- ☒ Complete Beamline Solutions
- ☒ Spectrometers
- ☒ Refractive Optics
- ☒ Foil Collimators
- ☒ Positioning

Contact JJ X-Ray A/S

If you have any questions, concerns, request for quotations or need general advice, please feel free to contact us:

JJ X-Ray A/S
Scion-DTU, Dr. Neergaards Vej 5D
2970 Hoersholm
Denmark

Telephone: +45 4776 3000
Fax: +45 4776 3001
VAT: DK 29523215

info@jjxray.dk
sales@jjxray.dk
Website: www.jjxray.dk